

Types of spindle nose

DIN 55026 TYPE A1 - A2

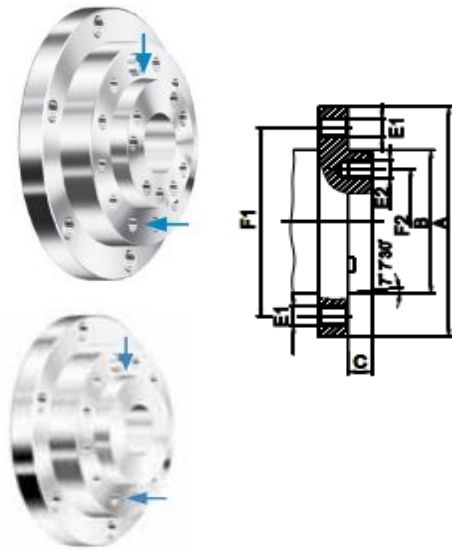

KK/ Cone	F1 (A2) mm	F2 (A1) mm	B mm	C mm	E1 / E2
4	82,6	-	63,521	11	M10
5	104,8	61,9	82,573	14,288	M10
6	133,4	82,6	106,385	15,875	M12
8	171,4	111,1	139,731	17,462	M16
11	235	165,1	196,883	19,05	M20
15	330,2	247,6	285,791	20,638	M24
20	463,6	368,3	412,795	22,225	M24

Type A1 : With threaded holes in bolts inside and out

Type A2 : Without hole on inner bolt

DIN 55027 TYPE C

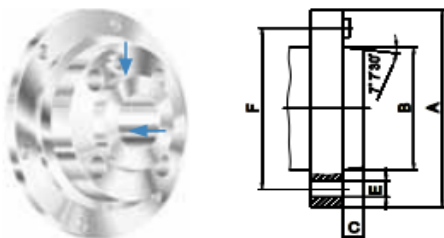

KK/ Cone	A mm	F mm	B mm	C mm	E mm	Hole
3	102	75	53,983	11	21	3
4	112	85	63,521	11	21	3
5	135	104,8	82,573	13	21	4
6	170	133,4	106,385	14	23	4
8	220	171,4	139,731	16	29	4
11	290	235	196,883	18	36	6
15	400	330,2	285,791	19	43	6

DIN 55029 Camlock Type D1

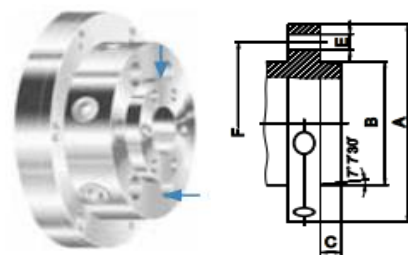

KK/ cone	A mm	F mm	B mm	C mm	E mm	Hole
3	92	70,6	53,983	11	15,1	3
4	117	82,6	63,521	11	16,7	3
5	146	104,8	82,573	13	19,8	6
6	181	133,4	106,385	14	23	6
8	225	171,4	139,731	16	26,2	6
11	298	235	196,883	18	31	6
15	403	330,2	285,791	19	35,7	6